



GONGE®

2024/25

We help create

MOMENTOUS LITTLE MOMENTS®





CURIOUS AND PLAYFUL SINCE 1966

Every day, someone is introduced to GONGE® for the first time and it will feel like discovering something new. However, although our current range contains items that are indeed new, it also features perennial classics that today's adults will fondly remember from their childhood. Products that have been a staple of the professional and institutional childcare sector for over 50 years.

Play is the inspiration for all GONGE® products, which are carefully designed to challenge children's physical limits, develop their cognitive skills, encourage social interaction and support emotional integrity. We believe that the development of body and mind is essential for building the confidence that children will depend on throughout life.

Every child is unique and deserves individual attention to help them develop while they play. We care for the specific needs of each child at the functional level they

require, helping them to grow to reach new developmental stages through playful stimulation and therapeutic training. They may even use our products for training and rehabilitation in later life (pages 84-85).

Our stimulating range of products combines educational principles, beautiful design, excellent quality and the highest safety standards. We remain loyal to our origins as a supplier to the educational market, yet our creative approach to learning has become increasingly popular with families as well.

FIND YOUR FAVOURITES

Alphabetical order page

ACTIVITY RINGS _____	79
AIR BOARD _____	68
ARCHES _____	16
BABY TRAMPOLINE _____	64
BALANCE PLASTIC HEMISPHERES _____	77
BALANCO _____	75
BLOW LOTTO _____	87
BODY WHEEL _____	22
BOUNCING RIVER STONE _____	37
BUILD N' BALANCE® _____	30-35
CAROUSEL _____	66
CLOWN'S HAT _____	80
CONES _____	36
CUSHION FOR MINI TOP _____	59
ENCOURAGING EXERCISE _____	85
FISHING ROD _____	51
FLOOR SURFER® _____	54
GIANT AIR BOARD _____	71
GIANT BALANCING BOARD _____	74
GO GO / GO GO BUS _____	57
HEMISPHERE STILTS _____	77
HILLTOPS _____	41
HULA HOOPS _____	36
HUNGRY FISH _____	51
ISLAND _____	44
JOINTS _____	36
KOALA / NON SLIP SHOES _____	63
MAGIC SCARVES _____	85
MINI PARKOUR® _____	24-29
MINI STILTS _____	76
MINI TOP _____	59
MOTOR SKILLS DEVELOPMENT SET _____	13
NORDIC COLLECTION _____	11
PARACHUTE _____	84
RING TOSS _____	86
RIVER _____	44
RIVER LANDSCAPE _____	45
RIVER STONES _____	40
RIVER STONES MAXI _____	40
ROCK AROUND _____	74
ROLLER _____	19
ROUND SEESAW _____	74
SEESAW _____	73
SHIMMER FISH _____	51
STICKS _____	36
SWNX / MINI SWNX / HANGER _____	53
TACTILE DISCS _____	48
TACTILE RIVER STONES _____	46
THERAPY TOP _____	75
THERAPY TOP - EPP _____	75
THROWING GAME _____	86
TOP _____	60
TRAMPOLINE _____	64
WIPPSIDER _____	75

By article number page

2006 _____	87
2095 / 2097 _____	63
2098 / 2099 _____	59
2100 / 2101 _____	60
2102 / 2104 / 2106 _____	74
2115 _____	46
2116 - 2118 _____	48
2120 _____	40
2121 _____	41
2123 _____	44
2124 _____	45
2126 _____	37
2127 _____	80
2128 _____	77
2130 _____	37
2131 / 2136 / 2138 / 2139 _____	57
2140 _____	75
2142 _____	75
2144 _____	75
2163 _____	16
2166 _____	45
2167 _____	66
2168 _____	54
2169 _____	73
2179/2184 _____	68
2181 _____	75
2185 _____	71
2190 / 2191 _____	79
2195 _____	76
2219 _____	77
2222 / 2224 / 2225 / 2228 / 2235 / 2236 _____	34
2223 / 2226 / 2227 / 2231 / 2232 / 2233 _____	35
2237 _____	33
2238 _____	33
2239 _____	33
2240 _____	33
2250 - 2255 _____	36
2266 - 2267 _____	19
2268 - 2270 _____	22
2280 / 2281 / 2282 / 2283 / 22787 / 2290 _____	36
2284 / 2285 / 2286 / 2288 / 2299 _____	27
2301 - 2305 _____	84
2306 / 2307 _____	85
2315 / 2316 / 2317 _____	51
2320 _____	40
2400 / 2406 _____	64
2501 / 2502 / 2503 _____	53
2600 _____	13
2907 / 2908 _____	86
2914 - 2919 _____	85
2942 _____	75



NOVELTIES 2024

MINI PARKOUR® MEGA SET

The Mega Set offers a wide range of Mini Parkour elements specifically created for daycare and preschool settings. With 31 different elements, this comprehensive set is perfect for designing various parkour courses that will captivate and engage children of all skill levels.

See page 29



TACTILE FOAM ROLLERS

Challenging, inviting and fun, these Tactile Foam Rollers are perfect for children to enhance their motor skills. They provide an opportunity to exercise agility and strength while helping children develop a sense of their boundaries.

GRIPS

Children can easily create more challenging courses with Mini Parkour® Grips. These innovative grips provide small platforms for hands, knees, or feet while navigating a Mini Parkour® course.

LONG BARS

Mini Parkour® Long Bars is designed to enhance the Mini Parkour® experience by providing a longer bar for connecting Hurdles. This versatile addition enables participants to engage in thrilling activities that demand more surface area, such as attempting somersaults or conquering greater distances while navigating the Mini Parkour® course.

STORAGE TROLLEY

Make storage easier and more practical with our Storage Trolley. It features a sturdy plywood base and four swivel wheels, making it easy to maneuver and transport. Storage Trolley is designed specifically to accommodate Mini Parkour® Mega Set, allowing you to keep all the elements organized and easily accessible. Don't let the clutter get in the way of your parkour fun - keep everything neatly stored and ready to go with Storage Trolley.

AIRBOARD



Introducing Air Board and Giant Airboard, now showcasing enhanced quality and vibrant new colours. This versatile product is perfect for people of all ages, making it ideal for both training and playful activities. The inflatable cushion provides a bouncy and dynamic experience, setting it apart from regular balance boards.

See pages 68-71





WE HELP CREATE

MOMENTOUS LITTLE MOMENTS®

At GONGE®, we make products that inspire and motivate children to be physically active right from the beginning of their lives, helping them to learn and develop motor skills through play - creating Momentous Little Moments®.

Although GONGE® is founded on a whole spectrum of profound neuro-pedagogical, sensory-motorial and educational principles, the benefits of using our products are experienced simply and often subconsciously. At GONGE®, we love the satisfaction of knowing what a long-term difference this will make for each child.



Find inspiration
and share your
Momentous Little Moments

@gongeoofficial

GONGE INSIGHTS

Gain insight into the world of motor skills and sensory integration through our compelling case studies.

GONGE® issues a quarterly newsletter, called Gonge Insights, edited by a child physiotherapist. Each newsletter includes a short introduction to a specific sensory ability or motor skill, together with a presentation of a GONGE® product relevant for training this ability.

The theoretical introduction is followed by a case study illustrating how the child physiotherapist has worked on training this ability with a child in a clinical setting. See all previous issues of GONGE® Insights or subscribe for future issues by scanning the QR code below.

Case study by
child physiotherapist



Access
Insights cases

ACTIVITY COMPENDIUM

We are proud to introduce a collection of inspirational activities that you can do with children using our products.

The GONGE® Activity Compendium contains a library of over 160 short activity videos which are freely accessible on <http://www.learning.gonge.com>. We have found that video recordings are the best way to

convey our passion for helping children to be physically active. Make the printed compendium come alive by scanning the QR codes below to watch the videos on our website.

160 free activity videos
Developed with child
physiotherapist.

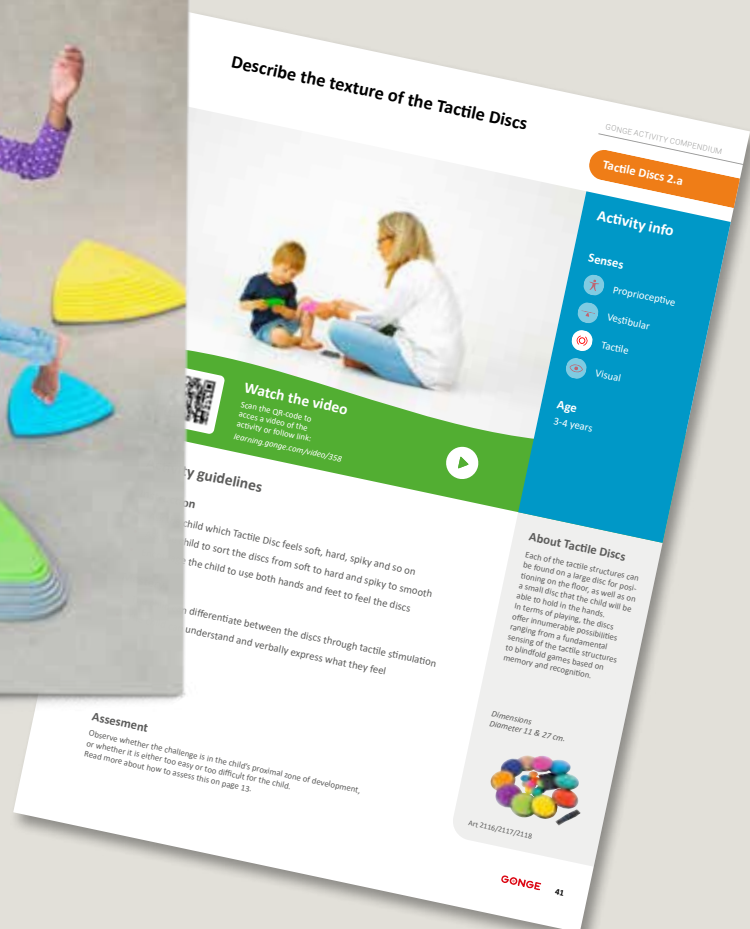

Download the
compendium



NORDIC COLLECTION

*Indulge your little ones with GONGE® Nordic Collection.
A world of potential, limited only by a child's imagination.*

GONGE® Nordic Collection comprises worldwide best-selling products: River Stones, Hilltops, River, Tactile Discs, Floor Surfer, Mini Top and Activity Rings. Now, these elegant and aesthetically pleasing designs have been given a distinctive Nordic touch, featuring colours from a subtle, Scandinavian palette. Distinctive enough for a child to notice but easier on the eye inside the home.



Light, natural and minimalist – yet still on a child's level. Adorable, purposeful products which contribute to their motor development.



See and download Gonge Nordic Catalogue





MOTOR SKILLS DEVELOPMENT SET

Complete Motor Skills Development Set comprising our most popular GONGE® products! Play is the basis for learning, and the Motor Skills Development Set provides ample opportunity for fun play, both individually and in groups. This helps to enhance children’s motor, cognitive and social skills, as well as stimulating their senses and colour awareness. Several of the products also include a guide to help inspire both play and learning.

Art 2600 contains the following products:

- Floor Surfer** | Art 2168
- Giant Top** | Art 2100
- Clown’s Hat x 2** | Art 2127
- Seesaw I** | Art 2169
- Activity Rings** | Art 2191
- Tactile Discs** | Art 2117
- River Stones** | Art 2120
- Hilltops** | Art 2121
- River** | Art 2123

Motor Skills Development Set® | Art 2600

	Set size (cm)			Export carton weight kg	Export carton volume m ³
	L	W	H		
	80	61	82	25.60	0.400



SHARE YOUR
MOMENTOUS LITTLE MOMENTS®



@gongeofficial



join us on Instagram
and get inspired





PHYSICAL

GONGE® products can be used for anything from free play to specific therapy and structured training. Children will develop **physical strength** and **motor skills** – including weight transfer, familiarity with heights, physical coordination and agility – as well as **sensorimotor abilities**, such as awareness of posture, sense of touch and balance.



SOCIAL

GONGE® encourages children to engage in games that combine physical and social abilities. Children compete, race, role play and perform using our products. Group play will help to teach them **cooperation** and **coordination** based on physical interaction. They will then learn by **imitating the actions** of others – probably our most basic way of learning.



EMOTIONAL

When a child jumps down from a GONGE® Hilltop or walks on River Stones, it is not just a matter of landing safely or keeping their balance. These experiences allow children to develop a general **emotional robustness** and **confidence** in their ability to master challenges. These physical activities make important contributions to a child's **self-confidence** at an early age, which will be vital in later life.



COGNITIVE

Body and mind cannot be regarded as separate. Basic cognitive functions, such as **memory, concentration, problem solving** and **spatial orientation**, are all vital for many of the physical activities inspired by GONGE®. This can be anything from estimating the distance before a jump to developing new language skills when naming or sorting physical activities.

ARCHES

Multipurpose Arches designed to allow children to invent new ways of playing and create motor challenges; the possibilities are endless. An Arch can be placed either with the curved side up – forming a bridge – or down, turning it into a seesaw. Several Arches may be combined to form long extended pathways, or even placed on top of each other to amuse the more adventurous children. Arches will inspire children to find new ways of challenging themselves, limited only by their imaginations. GONGE® believes in offering products that will stretch children’s creativity, and Arches is no exception. Pleasant to touch, the Arches consist of a stable plastic core with a soft rim made from artificial rubber, providing anti-slip edges. A set of three sturdy Arches.

Maximum load: 75 kg.

Arches | Art 2163

Made of: PP and TPE	Age	Product size (cm)			Single unit box weight kg	Single unit box volume m ³	Number of units in export carton	Export carton weight kg	Export carton volume m ³
		∅	L	W					
Set of 3 pcs.	2+	59	21.5	10.5			1	6.4	0.027

Design: Harrit & Sørensen
 EU Design Registration No. 455484-0001
 Patent No. ZL 2018 3 0308790.9



Scan QR for more inspiration.

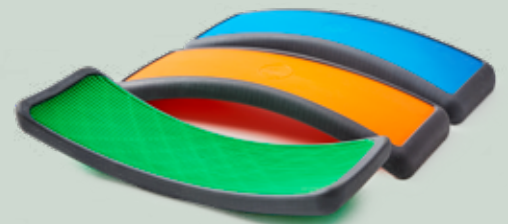

Art 2163





DANISH DESIGN AWARD
FINALIST
2016



ROLLER

Roller is a beautiful new conceptualisation of a fundamentally challenging motor activity object. Leave it out, and you will see both children and grown-ups tempted to test their skills by stepping up and trying to set the Roller in motion. It offers a progressive motor skills challenge, from small kids just managing to keep their balance with the support of a friend or a hand rail, to older children pushing the boundaries of what they can do without falling off. Whether it is used for play or in therapy, the Roller will stimulate the primary proprioceptive sense, as well as the vestibular and tactile senses.

Roller is safe to use, as the compression of its rubber tyres naturally reduces the speed while making play virtually silent and protecting the ground surface from damage. The rubber tread provides a safe grip and offers additional tactile stimulation when rolling with bare feet. For younger children, the green version of the Roller contains 2.5 kg of sand, further reducing the speed and enabling even small children to master balancing and rolling.

Maximum load 100 kg.

Roller with sand | Art 2266

Made of: PP, TPE rubber and sand. Colours: Green and grey.	Age	Product size (cm)			Single unit box weight kg	Single unit box volume m ³	Number of units in export carton	Export carton weight kg	Export carton volume m ³
		Ø	L	W					
	4+	29.5	35		5.80	0.029	3	18.20	0.099

Roller without sand | Art 2267

Made of: PP, TPE rubber and sand. Colours: Orange and grey.	Age	Product size (cm)			Single unit box weight kg	Single unit box volume m ³	Number of units in export carton	Export carton weight kg	Export carton volume m ³
		Ø	L	W					
	6+	29.5	35		3.50	0.029	3	11.00	0.099

EU Design Registration RCD 0027372588-0001. Patent No. ZL 2015 3 0255745.8



Scan QR for more inspiration.



Art 2267



Art 2266



*"It's easy to make things difficult,
but difficult to make them easy."*

Thomas Harrit, designer

"Instead of guessing, we calculate."

Claus Molgaard, production engineer

*"We must motivate children
by inspiring their play."*

Hannah Harboe, physiotherapist

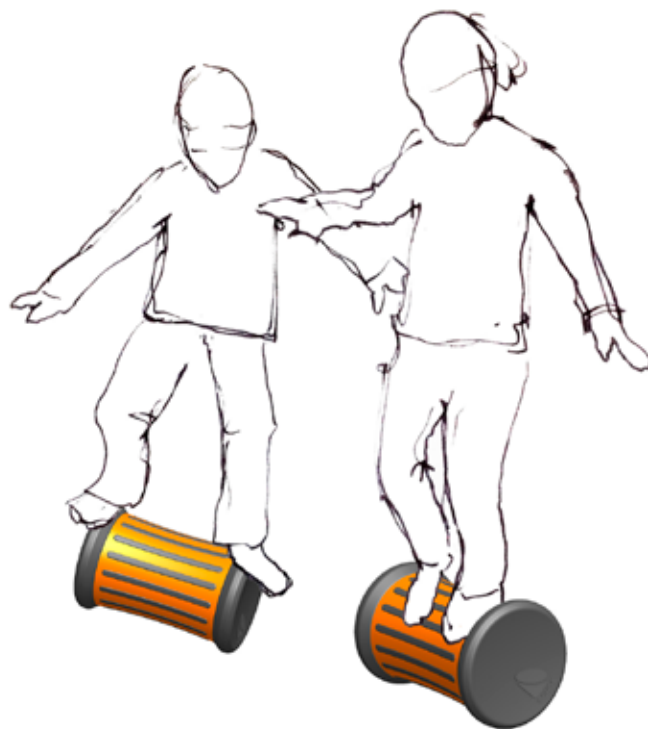

*Designing the right products
can be hard work, but we never
forget play and joy during that
process. Without fun, our toys
will not motivate children to
move and develop new skills.*

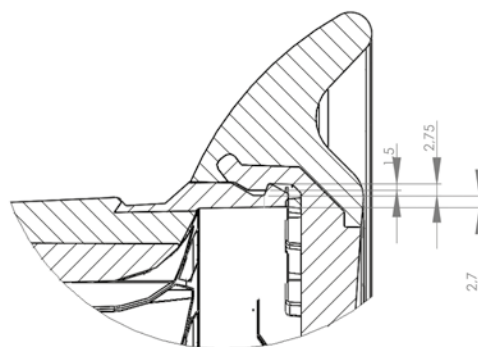
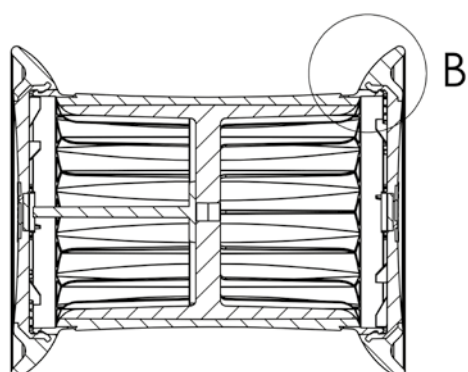
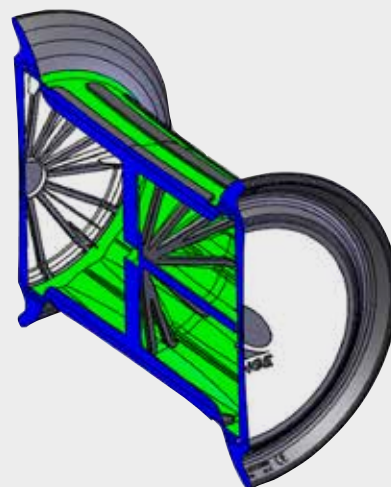

CAREFUL THINKING CREATES THE JOY OF SIMPLICITY

GONGE's simple designs contain worlds of potential. It takes careful thinking to create basic shapes and a variety of functions that are limited only by a child's imagination.



It all starts with observations

GONGE's designers spend hours observing children play to develop inspirational ideas for creative activities – sometimes they even play themselves! They discuss possibilities with our physiotherapist and then, when the ideas take shape, they put them to the test.

We follow a number of strict guidelines when developing GONGE® products. They should be safe and ergonomically correct. They aim at training selective sensing as well as sensory integration. They should contain the possibility of progression, when the children use it and improve their skills. And they should inspire social play.

Testing and trying, from idea to product

Initial drawings are discussed and examined extensively. Is the idea simple enough? Does it provide numerous ways to play? What senses and skills does it stimulate? Prototypes – either 3D prints or wooden models – are tried, tested and judged in real life. Do the children use the toy in the ways we envisioned? Can smaller children benefit?

Along the way, the design may be modified to prepare it for the final test: can it be produced as a safe, long-lasting product that will give children all over the world thousands of hours of play and help them to develop their skills? Only once everything has been simulated and analysed will GONGE® put the idea into production.

BODY WHEEL

Body Wheel is play equipment, of which some functions are mobile and unpredictable while others are static and stable.

Children love the easily recognisable drum and soon become absorbed in making the Body Wheel roll. The width of the small and large versions of the Body Wheel respectively inspire children of all ages to crawl inside and explore the Body Wheel's movements while sitting, lying or kneeling inside the

wheel. Children soon discover that it is also possible to roll on the outside of the Body Wheel. For compact storage, the small Body Wheel fits inside the large Body Wheel.

Body Wheel can be used in play and for training, indoors and out.

Soft artificial rubber rims protecting children from squeezing fingers or toes and from damaging the floor.

Maximum load 100 kg.

Body Wheel Small | Art 2268

Made of: Fibreglass-reinforced PP with TPE.	Age	Product size (cm)			Single unit box weight kg	Single unit box volume m ³	Number of units in export carton	Export carton weight kg	Export carton volume m ³
		Ø	L	W					
	3+	46	30		4.25	0.067	1	4.25	0.067

Body Wheel Large | Art 2269

Made of: Fibreglass-reinforced PP with TPE.	Age	Product size (cm)			Single unit box weight kg	Single unit box volume m ³	Number of units in export carton	Export carton weight kg	Export carton volume m ³
		Ø	L	W					
	3+	59	29		5.70	0.108	1	5.70	0.108

Body Wheels Set of small and large | Art 2270

Made of: Fibreglass-reinforced PP with TPE.	Age	Product size (cm)			Single unit box weight kg	Single unit box volume m ³	Number of units in export carton	Export carton weight kg	Export carton volume m ³
		Ø	L	W					
Set of 2 pcs.	3+	59	30		9.65	0.108	1	9.65	0.108

Design: Harrit & Sørensen

EU Design Registration No. 0006267159-0001/2.

Patent ZL-2019 3 0444308.9



Scan QR for more inspiration.





MINI PARKOUR®

Mini Parkour can be tailored to challenge the child's motor skills. The child develops muscular strength, flexibility and sensory integration generally. Mini Parkour is also a meeting place for children, where they can interact socially and exercise cognitive skills, such as planning and spatial orientation.

Mini Parkour elements are easy to connect and separate for practical storage. The elements are suitable for use indoors and out. Mini Parkour is specially designed for children aged 3-6 years. The robust elements are safe for children to use.



SLIDE

This versatile addition to the Mini Parkour range fosters children's creativity in building new courses, and encourages them to push the boundaries of their physical abilities. The slide is made from one piece of strong plastic and is mounted onto the Mini Parkour – Straight Hurdles and Mini Parkour® – Diagonal Hurdles, where integrated grips lock it firmly in place. Maximum load 50 kg.



CROSSBARS & LONG BARS

Crossbars & Long Bars can easily be mounted onto hurdles creating obstacles children have to crawl below or for climbing on top of the crossbars without touching the ground. The simple locking mechanism ensures that the crossbars fit securely, locking the elements together and making it safe for children to use.



Scan QR
for more
inspiration.



GRIPS

Children can easily create more challenging courses with Mini Parkour® Grips. These innovative grips provide small platforms for hands, knees, or feet while navigating a Mini Parkour® course. Grips have a safe and easy-to-use locking mechanism, making it effortless for children to attach them onto Mini Parkour® Hurdles. With a PP core and anti-slip artificial TPE surface, Mini Parkour® Grips ensure safety and stability.



MINI PARKOUR®

Mini Parkour - Base | Art 2280

Made of: PP with TPE rim. Maximum load 100 kg. Individual unit.	Age	Product size (cm)				Single unit box weight kg	Single unit box volume m ³	Number of units in export carton	Export carton weight kg	Export carton volume m ³
		Ø	L	W	H					
	3-6	71	31	11,5	1.3	0.025	4	6.0	0.081	



Mini Parkour - Straight Hurdle | Art 2281

Made of: Powder coated aluminium with PP ends. Maximum load 50 kg. Set of 2.	Age	Product size (cm)				Single unit box weight kg	Single unit box volume m ³	Number of units in export carton	Export carton weight kg	Export carton volume m ³
		Ø	L	W	H					
	3-6	2,5/4,5	77,5	59	1.9	0.041	4	8.9	0.178	



Mini Parkour - Diagonal Hurdle | Art 2282

Made of: Powder coated aluminium with PP ends. Maximum load 50 kg. Set of 2 pcs.	Age	Product size (cm)				Single unit box weight kg	Single unit box volume m ³	Number of units in export carton	Export carton weight kg	Export carton volume m ³
		Ø	L	W	H					
	3-6	2,5/4,5	72,5	48	1.4	0.031	4	6.7	0.147	



Mini Parkour - Crossbars | Art 2283

Made of: ABS Colour: Red Maximum load 50 kg. Set of 3 pcs.	Age	Product size (cm)				Single unit box weight kg	Single unit box volume m ³	Number of units in export carton	Export carton weight kg	Export carton volume m ³
		Ø	L	W	H					
	3-6	44	6	4,5	1.1	0.004	8	9.4	0.044	



Mini Parkour - Longbars | Art 2287

Made of: ABS Colour: Red Maximum load 50 kg. Set of 2 pcs.	Age	Product size (cm)				Single unit box weight kg	Single unit box volume m ³	Number of units in export carton	Export carton weight kg	Export carton volume m ³
		Ø	L	W	H					
	3-6	84	6	4,5	1.3	-	4	5.9	0.022	



Mini Parkour - Starter Set | Art 2290

The Starter Set includes the parts needed for children to construct their first basic courses.

6 Crossbars 2 Diagonal Hurdles 2 Straight Hurdles 4 Bases	Age	Product size (cm)				Single unit box weight kg	Single unit box volume m ³	Number of units in export carton	Export carton weight kg	Export carton volume m ³
		Ø	L	W	H					
	3-6	-	-	-	-	10.3	-	1	12.5	0.159



MINI PARKOUR®

Mini Parkour - Grips | Art 2288

Made of PP and TPE Colour: Blue. Maximum load: 50 kg.	Age	Product size (cm)				Single unit box weight kg	Single unit box volume m ³	Number of units in export carton	Export carton weight kg	Export carton volume m ³
		Ø	L	W	H					
Set of 4 pcs.	3-6	13	7	5	0.6	-	8	1	0.015	



Mini Parkour - Tactile Foam Rollers | Art 2286

Made of ABS, PP, nylon, steel and EVA. Colours: Orange and Blue. Maximum load: 50 kg.	Age	Product size (cm)				Single unit box weight kg	Single unit box volume m ³	Number of units in export carton	Export carton weight kg	Export carton volume m ³
		Ø	L	W	H					
Set of 2 pcs.	3-6	15	44		3.1	0.02	4	3.5	0.092	



Mini Parkour® - Hanging plank | Art 2284

Made of PP, TPE and steel Colour: Orange and grey. Maximum load 50 kg.	Age	Product size (cm)				Single unit box weight kg	Single unit box volume m ³	Number of units in export carton	Export carton weight kg	Export carton volume m ³
		Ø	L	W	H					
Individual unit.	3-6	55	15	50	1.1	0.007	4	5.2	0.035	

Patent No. ZL 2023 3 0274054.7



Mini Parkour® - Slide | Art 2285

Made of PP. Colour: Blue. Maximum load 50 kg.	Age	Product size (cm)				Single unit box weight kg	Single unit box volume m ³	Number of units in export carton	Export carton weight kg	Export carton volume m ³
		Ø	L	W	H					
Set of 2 pcs.	3-6	43.7	28.5	8.1	2.55	0.016	4	10.9	0.058	

Patent No. ZL 2023 3 0274050.9

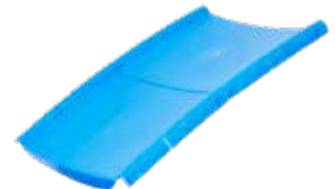

Mini Parkour® Storage Trolley | Art 2299

Made of plywood and 4 swivel wheels	Age	Product size (cm)				Single unit box weight kg	Single unit box volume m ³	Number of units in export carton	Export carton weight kg	Export carton volume m ³
		Ø	L	W	H					
Individual unit.	3-6	112	76	33	16.6	-	1	18.3	0.12	



Design: Harrit & Sørensen

EU Design Registration No. DM/212743.

Patent No. ZL 2021 3 0456828.9 2022030301393620



MINI PARKOUR® MEGA SET

The Mega Set offers a wide range of Mini Parkour elements specifically created for daycare and preschool settings. With 31 different elements, this comprehensive set is perfect for designing various parkour courses that will captivate and engage children of all skill levels.

Not only does the Mega Set challenge children's physical strength and agility, but it also fosters the development of important cognitive skills such as planning and imagination. By navigating through these elements, children will learn to strategize and think critically, enhancing their cognitive abilities in a fun and exciting way.

Furthermore, the Mini Parkour elements included in this set encourage the development of essential social skills like communication and cooperation. As children interact and collaborate with their peers to complete the parkour courses, they naturally learn to work together, effectively communicate, and engage in meaningful cooperation.

The Mega Set is the ultimate solution for daycare and preschool environments, providing limitless opportunities for children to engage in physical activity, cultivate vital cognitive skills, and foster positive social interactions.

Mini Parkour® Mega Set | Art 2291

8 Bases 4 Straight Hurdles 4 Diagonal Hurdles						
6 Crossbars 2 Slides 1 Hanging Plank 2 Tactile Foam Rollers with different structures 4 Grips						
	Age	Product size (cm)			Netweight	Number of
		Ø	L	W	H	kg
Set of 31 Elements	3-6					26.6
						1



Art 2288



Art 2286

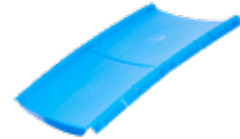

Art 2285



Art 2284



Art 2283



Art 2282



Art 2281



Art 2280

BUILD N' BALANCE®

The range of elements within Build N' Balance® allows you to create unique and versatile balancing courses tailored to improve the motor skills and exercise the balancing skills of children of all ages.

Build N' Balance® offers children the opportunity to construct either a long, straight balancing bridge or a circular obstacle course. Short courses are great for introducing balance to younger children, whereas a

course featuring various elevations and angles can provide an increased challenge for older children. Repeating the course can help them build confidence in their skills and achieve mastery.

Build N' Balance® offers a great tactile experience for children who are barefoot. The uniform surface provides good balance and the varied surface is a great way to challenge and motivate older kids. Use the difficult rocking planks and Tilting Disc for more advanced balance training.



TACTILE SENSORY TRAINING

The attractive colors of the Build N' Balance® elements capture children's attention and invite them to touch and explore. With a tactile structure that is straightforward to identify, children can become acquainted with the elements simply by walking barefoot or by touching. This addition to the existing Build N' Balance® products has the potential to enhance various activities, specifically in regard to tactile sensory training.



SMART COUPLING SYSTEM

Children can construct a trail with ease using the cleverly designed coupling system. Furthermore, they are able to tailor the difficulty of the course by taking advantage of the three adjustable heights, allowing them to create a unique and enjoyable balancing course.



STARTER, INTERMEDIATE, ADVANCED & TACTILE

If you're looking to get started with Build & Balance®, we have designed four distinct sets. Starter Set provides an easy introduction, and is suitable for those just starting out. Intermediate Set includes a variety of options, providing a bit more complexity. Advanced Set contains an abundance of diverse activities, providing an engaging experience for even the most experienced users. Finally, Tactile Set encourages tactile sensory training





BUILD N' BALANCE®

Build N' Balance® Starter Set | Art 2240

For those who are new to Build & Balance®, the Starter Set is a great way to commence their journey. It provides an easy introduction to construct courses.

This set includes: 3 Top10 2 Top24 2 Planks 3 Log Planks	Age	Product size (cm)			Single unit box weight kg	Single unit box volume m ³	Number of units in export carton	Export carton weight kg	Export carton volume m ³
		∅	L	W					
	2+					1	11.3	0.102	



Build N' Balance® Intermediate Set | Art 2238

The Intermediate Set offers a greater variety of courses, as well as more challenging options, for those looking for an extra challenge.

This set includes: 3 Top10 3 Top24 3 Planks 2 Log Planks 1 Rocking Plank 1 Tilting Disc	Age	Product size (cm)			Single unit box weight kg	Single unit box volume m ³	Number of units in export carton	Export carton weight kg	Export carton volume m ³
		∅	L	W					
	3+				15.00	0.163	1	15.00	0.163



Build N' Balance® Advanced Set | Art 2239

Children have the opportunity to be imaginative and inventive with the Advanced Set, allowing them to construct courses that contain a wide variety of challenging obstacles. It's the perfect way to test their innovation and problem-solving skills.

This set includes: 6 Top10 2 Top24 3 Planks 3 Log Planks 2 Bridge Piers 1 Slack Line 1 Rocking Plank 3 Sticks 1 Pair of Joints 1 Tilting Disc	Age	Product size (cm)			Single unit box weight kg	Single unit box volume m ³	Number of units in export carton	Export carton weight kg	Export carton volume m ³
		∅	L	W					
	3+				20.5	0.232	1	20.5	0.232



Build N' Balance Tactile Set | Art 2237

Three tactile elements designed for use with the Build N' Balance® set encouraging tactile sensory.

6 Tactile Planks, 3 Top24 and 3 Top10. Made of: PP and TPE.	Age	Product size (cm)			Single unit box weight kg	Single unit box volume m ³	Number of units in export carton	Export carton weight kg	Export carton volume m ³
		∅	L	W					
	3+				16.2	0.153	1	16.2	0.153



Design: Arne Egholm

EU Design Registration No. 001248967-001-004.

Patent No. ZL 201230340321.8, ZL 2012.30340374.X



Scan QR
for more
inspiration.

BUILD N' BALANCE®

Build N' Balance® Planks | Art 2222

The very robust Plank is a core element providing children the easiest and safe connection between Tops.

Made of: Steel-reinforced PP. Set of 3 Planks. Maximum load 100 kg.	Age	Product size (cm)			Single unit box weight kg	Single unit box volume m ³	Number of units in export carton	Export carton weight kg	Export carton volume m ³
		Ø	L	W					
	2-10	72	13	3	4.00	0.010	3	12.80	0.035



2222

Build N' Balance® Log Plank | Art 2228

An element with a curved surface that requires the child's complete attention and body control to keep the balance.

Made of: PP. Maximum load 100 kg.	Age	Product size (cm)			Single unit box weight (kg)	Single unit box volume (m ³)	Number of units in export carton	Export carton weight (kg)	Export carton volume (m ³)
		Ø	L	W					
	3-10	73	13	6	1.10	0.006	3	3.80	0.020



2228

Build N' Balance® Slack Line | Art 2224

An element with a 5 cm wide by 68 cm long belt linking one top to another (not included). A really great balancing challenge! The Slack Line can be tightened if required.

Made of: Steel-reinforced PP. Polyester line and metal tightening mechanism. Maximum load 50 kg.	Age	Product size (cm)			Single unit box weight kg	Single unit box volume m ³	Number of units in export carton	Export carton weight kg	Export carton volume m ³
		Ø	L	W					
	4-10	72	12	9	2.00	0.009	3	6.60	0.030



2224

Build N' Balance® Rocking Plank | Art 2225

An element with an integrated rocking function, requiring the children to transfer their weight as they move from top to top (not included). The Rocking Plank moves 6 cm as it rocks.

Made of: PP. Maximum load 50 kg.	Age	Product size (cm)			Single unit box weight kg	Single unit box volume m ³	Number of units in export carton	Export carton weight kg	Export carton volume m ³
		Ø	L	W					
	3-10	72	13	11	2.00	0.011	3	6.50	0.041



2225

Build N' Balance® Wobbling Plank | Art 2235

Wobbling Plank rocks gently when balanced on, safely able to be used by small children thanks to restricted rocking.

Made of: PP, nylon, TPE and steel. Maximum load 50 kg.	Age	Product size (cm)			Single unit box weight kg	Single unit box volume m ³	Number of units in export carton	Export carton weight kg	Export carton volume m ³
		Ø	L	W					
	4-10	73	12	6	1.80	0.008	3	5.80	0.034



2235

Build N' Balance® Tactile Planks | Art 2236

Wobbling Plank rocks gently when balanced on, safely able to be used by small children thanks to restricted rocking.

Made of: PP and TPE. Maximum load 100 kg. Set of 3 pcs.	Age	Product size (cm)			Single unit box weight kg	Single unit box volume m ³	Number of units in export carton	Export carton weight kg	Export carton volume m ³
		Ø	L	W					
	3+	72.5	12.5	7	7.3	0.060	3	7.3	0.060



2236

BUILD N' BALANCE®



Build N' Balance® Top10 | Art 2226

The Tops are the unique Build N' Balance® part connecting all the other parts in any direction and at several levels. The Tops also serve a platform for regaining balance.

Made of: PP with non-slip TPE edges. Stackable for easy storage. Maximum load 100 kg.	Age	Product size (cm)			Single unit box weight kg	Single unit box volume m ³	Number of units in export carton	Export carton weight kg	Export carton volume m ³
		Ø	L	W					
	2-10	27		10	0.40	0.009	6	3.30	0.036



2226

Build N' Balance® Top24 | Art 2227

The Tops are the unique Build N' Balance® part connecting all the other parts in any direction and at several levels. The Tops also serve a platform for regaining balance.

Made of: PP with non-slip TPE edges. Stackable for easy storage. Maximum load 100 kg.	Age	Product size (cm)			Single unit box weight kg	Single unit box volume m ³	Number of units in export carton	Export carton weight kg	Export carton volume m ³
		Ø	L	W					
	2-10	40		24	1.10	0.038	6	8.10	0.109



2227

Build N' Balance® Bridge Pier | Art 2231

The Bridge Pier enables children to increase the difficulty by building longer and narrower bridges with fewer options to take a break.

Made of: PP with non-slip TPE edges. Maximum load 100 kg.	Age	Product size (cm)			Single unit box weight kg	Single unit box volume m ³	Number of units in export carton	Export carton weight kg	Export carton volume m ³
		Ø	L	W					
	3-10	37	30	25	0.60	0.029	6	4.80	0.053



2231

Build N' Balance® Tilting Disc | Art 2232

Tilting Disc strengthens proprioception and balance in children. Its two hard plastic parts connect around a thick, moveable rubber connector that shifts with gravity. Must be placed in Top10 or Top24.

Made of: PP, TPE and metal. Maximum load 50 kg.	Age	Product size (cm)			Single unit box weight kg	Single unit box volume m ³	Number of units in export carton	Export carton weight kg	Export carton volume m ³
		Ø	L	W					
	3+	22		13	1.00	0.008	6	6.60	0.053



2232

Build N' Balance® Tilting Disc Set | Art 2233

1 Top 10
1 Tilting Disc

Made of: PP, TPE and metal. Maximum load 50 kg.	Age	Product size (cm)			Single unit box weight kg	Single unit box volume m ³	Number of units in export carton	Export carton weight kg	Export carton volume m ³
		Ø	L	W					
	3+	22		17	1.50	0.017	6	9.90	0.104



2233

Build N' Balance® Triangular Platform | Art 2223

The Platform offers children a place to rest, regain courage and plan for the next move.

Made of: PP. Maximum load 75 kg.	Age	Product size (cm)			Single unit box weight kg	Single unit box volume m ³	Number of units in export carton	Export carton weight kg	Export carton volume m ³
		Ø	L	W					
	2-10	66	66	3	2.00	0.012	1	2.00	0.012



2223



CONES

A multi-functional cone that can be used for countless activities. The holes ($\varnothing = 25$ mm) make it possible to use the cones in combination with the sticks. The Hula Hoops can also be placed in the Cones. Stylish design in a range of bright colours.



Cones | Art 2250

Made of: PP.	Age	Product size (cm)			Single unit box weight kg	Single unit box volume m ³	Number of units in export carton	Export carton weight kg	Export carton volume m ³
		\varnothing	L	W					
Set of 6 cones in 6 colours.	2+	21		29	2.10	0.023	6	13.80	0.150

Design: Harrit & Sørensen



2250

JOINTS

Versatile Joint fitting our $\varnothing 25$ mm Sticks (Art 2251) and our Hoops (Art 2252, 2253 and 2254). Sticks can be mounted vertically and/or horizontally, and the Joint also has a grip that a Hula Hoop will fit into.

Joints | Art 2255

Made of: POM.	Age	Product size (cm)			Single unit box weight kg	Single unit box volume m ³	Number of units in export carton	Export carton weight kg	Export carton volume m ³
		\varnothing	L	W					
Set of 2 pcs.	2-	6.5	4	4	0.00	0.000	6 x 2	0.05	0.000



2255

STICKS

Set of 6 Sticks with rounded stoppers at each end. 100 x 2.5 cm. Fits with Cone (Art 2250) and Build N' Balance® Tops. (Art 2226 and 2227).

Sticks | Art 2251

Made of: ABS.	Age	Product size (cm)			Single unit box weight kg	Single unit box volume m ³	Number of units in export carton	Export carton weight kg	Export carton volume m ³
		\varnothing	L	W					
Set of 6 pcs.	2+	2.5	100		1.00	0.005	6	6.40	0.029



2251

HULA HOOPS

Strong Hula Hoops made for rough and tumble play without the risk of breaking. Can be combined with our Cones. Available in 35, 50 and 65 cm diameters.

Hula Hoops 35 cm | Art 2252

Made of: Nylon.	Age	Product size (cm)			Single unit box weight kg	Single unit box volume m ³	Number of units in export carton	Export carton weight kg	Export carton volume m ³
		\varnothing	L	W					
Set of 3 pcs. in 3 colours	2+	35			0.60	0.005	6	4.00	0.034

Hula Hoops 50 cm | Art 2253

Made of: Nylon.	Age	Product size (cm)			Single unit box weight kg	Single unit box volume m ³	Number of units in export carton	Export carton weight kg	Export carton volume m ³
		\varnothing	L	W					
Set of 3 pcs. in 3 colours	2+	50			0.90	0.010	6	5.80	0.066

Hula Hoops 65 cm | Art 2254

Made of: Nylon.	Age	Product size (cm)			Single unit box weight kg	Single unit box volume m ³	Number of units in export carton	Export carton weight kg	Export carton volume m ³
		\varnothing	L	W					
Set of 3 pcs. in 3 colours	2+	65			1.20	0.017	6	8.20	0.109

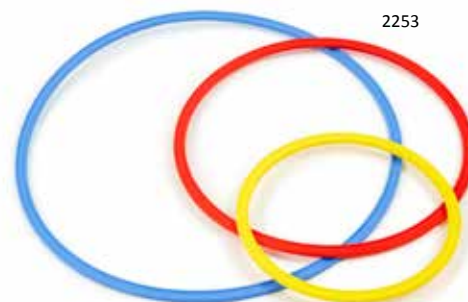

2253

2254

2252

BOUNCING RIVER STONE

This adaption of River Stone features a soft base and a hard top platform supported by three strong steel springs to enable bouncing, which requires adjustment through the child's ankles and legs, making it a more challenging activity than simply stepping. Bouncing River Stone can be used on its own for special motor training activities, or together with River Stones to provide even more play possibilities. Maximum load 50 kg.

Bouncing River Stone | Art 2126

Made of: PP, TPE and steel.	Age	Product size (cm)			Single unit box weight kg	Single unit box volume m ³	Number of units in export carton	Export carton weight kg	Export carton volume m ³
		Ø	L	W					
	2-14	36	37	10	1.60	0.013	4	6.80	0.066

Bouncing River Stone Set | Art 2130

Set of 1 Bouncing River Stone, 2 small River Stones and 2 large River Stones. Made of PP, TPE and steel.	Age	Product size (cm)			Single unit box weight kg	Single unit box volume m ³	Number of units in export carton	Export carton weight kg	Export carton volume m ³
		Ø	L	W					
	2-14				3.50	0.026	3	11.00	0.091

Design: Harrit & Sørensen
EU Design Registration No. 3746528-0003
Patent No. 201730030843.0



Scan QR
for more
inspiration.



Art 2126



Open view into tower with spring



Art 2130

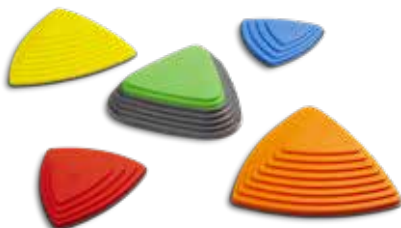





RIVER STONES

River Stones are designed to improve coordination and balance. Jumping or stepping from stone to stone develops a child's confidence in their ability to judge distances. The side of each triangular block varies in steepness and difficulty, and the layout can be changed to make a pathway more or less challenging. Each stone has a non-slip rubber rim, which also protects indoor surfaces. River Stones can be conveniently stacked for storage. Maximum load 100 kg.

River Stones | Art 2120

Made of: PP and TPE.	Age	Product size (cm)			Single unit box weight kg	Single unit box volume m ³	Number of units in export carton	Export carton weight kg	Export carton volume m ³
		Ø	L	W					
Set of 6 stones in 6 colours	2+				2.70	0.021	4	11.10	0.093
3 big stones		38	37	8.5					
3 small stones		26	26	4.5					



River Stones Maxi | Art 2320

Made of: PP and TPE.	Age	Product size (cm)			Single unit box weight kg	Single unit box volume m ³	Number of units in export carton	Export carton weight kg	Export carton volume m ³
		Ø	L	W					
Set of 9 stones in 6 colours	2+				15.3	0.013	4	16.9	0.052
3 big stones		38	37	8.5					
6 small stones		26	26	4.5					



Design: Harrit & Sørensen
Patent No. ZL201230344761.0



Scan QR
for more
inspiration.



HILLTOPS

Hilltops offer high play value and ample opportunity to develop and stimulate children’s gross motor skills, social skills and creativity. Five Hilltops of varying heights encourage children to jump from top to top, helping to develop the ability to estimate distances, while building a familiarity with heights. The Hilltops’ stable design makes them perfectly safe for jumping activities, and the other included games suggestions. Each Hilltop has a non-slip rubber rim, which also protects indoor surfaces.

Maximum load 100 kg.

Hilltops | Art 2121

Made of: PP and TPE.	Age	Product size (cm)			Single unit box weight kg	Single unit box volume m ³	Number of units in export carton	Export carton weight kg	Export carton volume m ³
		∅	L	W					
Set of 5 Hilltops in 3 heights	2+				4.8		1	5.6	0.068
2 Hilltops		38	37	8.5					
2 Hilltops		41	41	17					
1 Hilltop		43	43	26					

Design: Harrit & Sørensen



Scan QR for more inspiration.



QUALITY PRODUCTS

FOR A MORE SUSTAINABLE WAY OF LIFE

We fully support the emerging ecosystem

One of our ways of contributing to a more sustainable way of life

AFTER YEARS OF USE, OUR PRODUCTS ARE ALMOST AS GOOD AS NEW

Gonge products are designed for the toughest consumers: children. Usually, these children enjoy them in educational institutions but, as word has spread, more and more families are becoming keen customers. What surprises these families is that our products often survive so long, they can be passed on – or sold - to others. This explains why there is a growing demand for used Gonge items, which command prices of up to 50% of their brand new value.

We fully support this emerging ecosystem. Not only does it reduce waste, it exposes more children to Gonge. Which surely has to be a good thing.

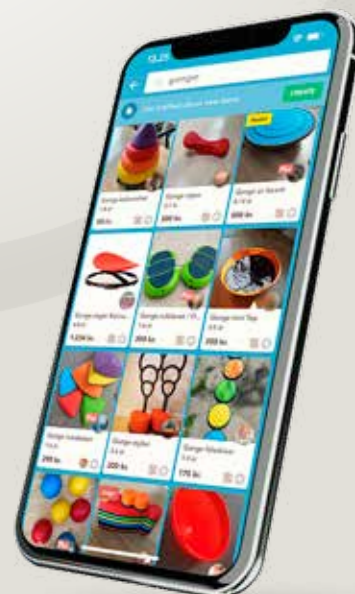

The growing demand for used Gonge items, command prices of up to 50% of their brand new value*



RIVER

River elements provide unlimited possibilities for building balance paths, and the size and easy joining mechanism make it suitable for small children. River can be combined with the Island, and can be stacked for storage.

Maximum load 100 kg.

River | Art 2123

Made of: PP with non-slip TPE edges. Set of 7 pcs.	Age	Product size (cm)			Single unit box weight kg	Single unit box volume m ³	Number of units in export carton	Export carton weight kg	Export carton volume m ³
		Ø	L	W					
	2-99				1.95	0.010	8	16.00	0.099
6 elements		35.5	11.5	4.5					
1 element		16	8.5	4.5					

Design: Harrit & Sørensen



Scan QR for more inspiration.

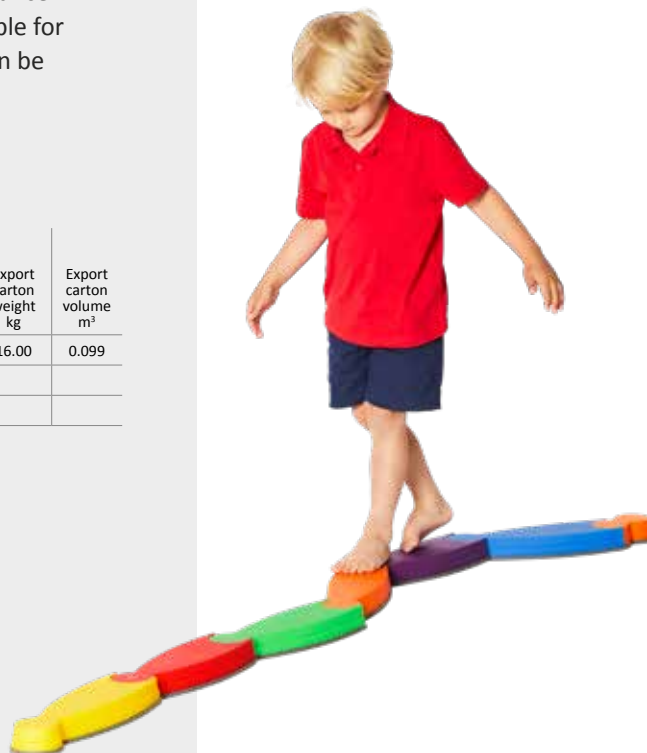

ISLAND

Island are elements designed to create totally new ways of playing and stimulating movement as a supplement to River. Combining Island with River gives innumerable options for building landscapes for balance and movement. The Island forms a natural junction or 'refuge', and links different elements together to make a challenging obstacle that children can balance on as they cross over. Maximum load 100 kg.

Island | Art 2124

Made of: PP with non-slip TPE edges. Set of 2 pcs.	Age	Product size (cm)			Single unit box weight kg	Single unit box volume m ³	Number of units in export carton	Export carton weight kg	Export carton volume m ³
		Ø	L	W					
	2+	30	43	8,5	1.22	0.012	8	10.38	0.100

Design: Harrit & Sørensen

EU Design Registration No. 463369-0001

Patent No. ZL 2023 3 0261174.3



Scan QR for more inspiration.



RIVER LANDSCAPE

An exciting balance landscape with no less than 25 elements that can be combined in any number of ways. The set provides lots of options for balance training, movement exercises and group play, and includes a number of play scenarios.

Maximum load 100 kg.

Set includes:

River (21 elements) + Island (4 elements)



Scan QR
for more
inspiration.

River Landscape | Art 2166

Made of: PP with TPE edges. 6 colours.	Age	Product size (cm)			Single unit box weight kg	Single unit box volume m ³	Number of units in export carton	Export carton weight kg	Export carton volume m ³
		Ø	L	W H					
	2-99				8.00	0.051	1	8.00	0.051

Design: Harrit & Sørensen



TACTILE RIVER STONES

A set of five different tactile structures embedded in a new version of River Stones. Five different materials cork, aluminum, foam, artificial rubber and concrete have been selected to create a variety of tactile sensations. The various tactile sensors perceiving hardness/compliance, temperature, roughness or stickiness are all activated to distinguish between these tactile structures. The slope of the surface increases pressure on the forefoot reinforcing the tactile stimulation. Suitable for free play as well as structured training. Maximum load 75 kg.

Tactile River Stones | Art 2115

Made of: PP with non-slip TPE edges.	Age	Product size (cm)			Single unit box weight kg	Single unit box volume m ³	Number of units in export carton	Export carton weight kg	Export carton volume m ³
		Ø	L	W					
Set of 5 pcs.	3+	28	35	8/17	3.9	0.021	4	18.3	0.092

Design: Harrit & Sørensen
 Patent No. ZL 2023 3 0261169.2





TACTILE DISCS

Tactile Discs challenge children's sense of touch, and their ability to describe sense impressions. The discs are made of synthetic rubber moulded into tactile surfaces, each with its own colour, and are available in two sizes: small and large for either hand-held or floor-based activities. Game options can be orientated around basic tactile sensing or memory and recognition using a blindfold.

Maximum load 100 kg.



2116

Tactile Discs – complete set | Art 2116

A set of 10 different tactile structures in a range of colours (10 large and 10 small discs), a blindfold and a large cloth bag.	Age	Product size (cm)			Single unit box weight kg	Single unit box volume m ³	Number of units in export carton	Export carton weight kg	Export carton volume m ³
	1+	Ø	L	W					
		11+27			5.20	0.032	3	16.00	0.110



2117

Tactile Discs – set 1 | Art 2117

Made of: ABS, TPE, Cotton, Steel, Velcro.	Age	Product size (cm)			Single unit box weight kg	Single unit box volume m ³	Number of units in export carton	Export carton weight kg	Export carton volume m ³
	1+	Ø	L	W					
		11+27			2.90	0.018	4	12.40	0.084

Tactile Discs – set 2 | Art 2118

Made of: ABS, TPE, Cotton, Steel, Velcro.	Age	Product size (cm)			Single unit box weight kg	Single unit box volume m ³	Number of units in export carton	Export carton weight kg	Export carton volume m ³
	1+	Ø	L	W					
		11+27			2.60	0.017	4	11.50	0.078



2118

Design: Dejbjerg Design

EU Design Registration No. 266010-0001 ... 0006



Scan QR
for more
inspiration.







SHIMMER FISH

The bright design of these fish captures the eye and boosts imaginations, helping children role-play with others while developing interpersonal skills and language. The steel core of the fish enables them to be hauled up with the magnetic boathook of the Fishing Rod (Art 2315). A thick rubber rim adds to their comfort and safety for all ages. Fishing with the rod improves perceptual and cognitive motor skills, as well as balance and hand-eye coordination.

Shimmer Fish | Art 2316

Made of TPE and steel.		Product size (cm)			Single unit box weight kg	Single unit box volume m ³	Number of units in export carton	Export carton weight kg	Export carton volume m ³
Colour: Blue, red, green and yellow.	Age	Ø	L	W					
Set of 4 pcs.	2-5	16	6	1.5	0.35	?	8	?	?

Design: Harrit & Sørensen
 Patent DM/225948
 Patent No. ZL2023 3 0274046.2

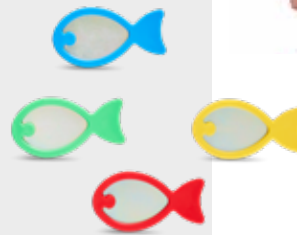

HUNGRY FISH

These brilliantly coloured fish have been cleverly designed to be hooked in the mouth using a 'hook and line' function on the Fishing Rod (Art 2315). This fun game requires motor skills and mental concentration, and encourages children to use forward planning and problem-solving skills. Children can also compete with each other, contributing to social awareness and language learning.

Hungry Fish | Art 2317

Made of TPE and PP.		Product size (cm)			Single unit box weight kg	Single unit box volume m ³	Number of units in export carton	Export carton weight kg	Export carton volume m ³
Colour: Grey, blue, red, green, and yellow.	Age	Ø	L	W					
Set of 4 pcs.	3-7	25	12.5	5.5			8	6.48	0.022

Design: Harrit & Sørensen
 Patent DM/225948
 Patent No. ZL2023 3 0274048.1

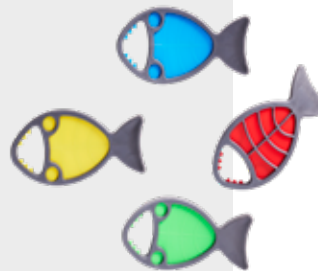

FISHING ROD

Fishing requires motor skills and mental concentration, and develops children's balance and hand-eye coordination. The fishing rod is well-suited, and can be adapted for use in imaginary and role-playing games involving interaction and language.

Fishing Rod | Art 2315

Made of: TPE and ABS. Strong ceramic magnet on underside of hook.		Product size (cm)			Single unit box weight kg	Single unit box volume m ³	Number of units in export carton	Export carton weight kg	Export carton volume m ³
	Age	Ø	L	W					
	2+	3.5	90		0.40	0.002	8	3.6	0.012

Design: Harrit & Sørensen
 EU Design Registration No. 001135826
 Patent No. ZL201230342844.6



High quality ceramic magnet

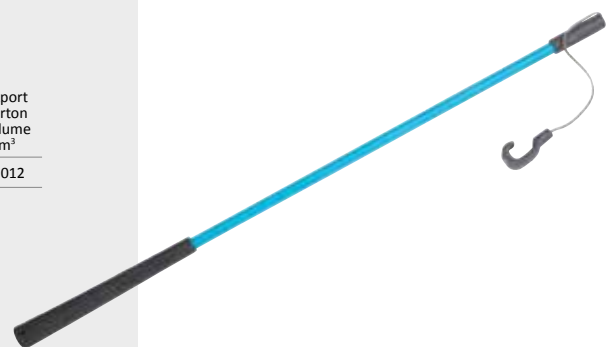

Scan QR for more inspiration.



MINI SWNX® AND SWNX®

Mini SWNX and SWNX are foot swings for children that are specially designed to be mounted under tables. When seated on a chair, the child's feet are placed on the SWNX, providing them with a reliable contact surface that improves their grounding.

Mini SWNX and SWNX foot swings are unique products that help boost concentration in physically active children. SWNX allows restless children to alleviate their urge to

move in an appropriate fashion, and may also help passive children to increase their enthusiasm.

Stable disc (PP plastic) with anti-slip structure (TPE) on a polyester rope, mounted in durable hanger (nylon). Maximum load 100 kg when mounted onto an appropriate table.

Mini SWNX® | Art 2501

Made of: PP and TPE and nylon plastic.	Age	Product size (cm)			Single unit box weight kg	Single unit box volume m ³	Number of units in export carton	Export carton weight kg	Export carton volume m ³
		Ø	L	W					
	3-7	21		75	0.58	0.003	6	3.78	0.020

SWNX® | Art 2502

Made of: PP and TPE and nylon plastic.	Age	Product size (cm)			Single unit box weight kg	Single unit box volume m ³	Number of units in export carton	Export carton weight kg	Export carton volume m ³
		Ø	L	W					
	6+	31		100	0.96	0.005	6	6.36	0.036

Hanger for SWNX® | Art 2503

Design: Peter Dubgaard/Resense
 EU Design Registration No. 007461819-0001
 Patent No. US D945,199 S
 Patent No. ZL 2020 3 0295837.X

Scan QR
 for more
 inspiration.



FLOOR SURFER®

Floor Surfer® is an appealing roller board combining function, safety and design to help train motor skills. It has been developed in partnership with children's physiotherapists to ensure safe use by any child for play or therapy, irrespective of motor skills level. Maximum load 100 kg.

Floor Surfer® | Art 2168

Made of: PP and EVA foam with PU wheels.	Age	Product size (cm)			Single unit box weight kg	Single unit box volume m ³	Number of units in export carton	Export carton weight kg	Export carton volume m ³
		Ø	L	W					
	½-10	57	39	14	2.60	0.031	4	11.20	0.092

Design: Harrit & Sørensen
EU Design Registration No . 10716488
Patent No. ZL 2022 3 0008412.5



Scan QR
for more
inspiration.





3



2



4



1

- 1) The protruding corners protect the child's hands when holding the narrow sides, which act as handles.
- 2) Floor Surfer® is slightly tapered at the front to give increased freedom of movement for the child's arms.
- 3) The raised front of Floor Surfer® supports the coccyx when the child is sitting, and the sternum when the child is lying down.
- 4) Quality, non-smudge, double ball-bearing wheels made of clear PU are screened to minimise the risk of running over the child's fingers.



GO GO

Go Go encourages exciting and challenging motor activity, developing body control. The third generation Go Go has a modern design reflecting the ambition to manufacture strong and beautiful product that is safe, stimulating, and fun to play with.

Maximum load 75 kg.

Go Go | Art 2138

Made of: PP wheels and pedals. Steel axle (Ø 14 mm) and TPE tyres.	Age	Product size (cm)			Single unit box weight kg	Single unit box volume m ³	Number of units in export carton	Export carton weight kg	Export carton volume m ³
	4+	Ø	L	W					
		36	50	15	3.50	0.031	4	15.00	0.135

Handles for Go Go | Art 2131

Pair of handles (45 cm height). Made of 12 mm diameter steel covered with surface-reinforced foam (diam. 30 mm in total).	Age	Product size (cm)			Single unit box weight kg	Single unit box volume m ³	Number of units in export carton	Export carton weight kg	Export carton volume m ³
	4-7	Ø	L	W					
					2.60	0.010	4	11.00	0.046

Design: Harrit & Sørensen



Scan QR for more inspiration.



GO GO BUS

Go Go Bus reflects our aim to manufacture sturdy and beautiful products, which are fun and safe for children and assist their motor development. When two or three children board the Go Go Bus, they have to coordinate their movements, which children find both challenging and fun. On the basis of years of experience, we have created Go Go and Go Go Bus to fulfill the quality requirements set forth by childcare centres.

Maximum load 75 kg.

Go Go Bus | Art 2139

Made of: PP wheels and pedals. Steel axle (Ø 14 mm) and TPE tyres.	Age	Product size (cm)			Single unit box weight kg	Single unit box volume m ³	Number of units in export carton	Export carton weight kg	Export carton volume m ³
	4+	Ø	L	W					
		59	50	15	4.80	0.052	3	15.60	0.170

Handles for Go Go Bus | Art 2136

Pair of handles (45 cm height). Made of 12 mm diameter steel covered with surface-reinforced foam (diam. 30 mm in total).	Age	Product size (cm)			Single unit box weight kg	Single unit box volume m ³	Number of units in export carton	Export carton weight kg	Export carton volume m ³
	4-7	Ø	L	W					
					3.60	0.024	3	11.5	0.080

Design: Harrit & Sørensen





MINI TOP

Mini Top encourages activities that are important for the early development of a child's sense of balance (the vestibular system) and motor control. The Mini Top invites young children to teeter, swing and spin around with the help of an adult, and then subsequently on their own. Safety is embedded into the Mini Top's simple yet functional design. The geometric shape ensures that the tilting motion gradually slows down and prevents the child from tipping over, while vertical edges ensure that the child's head and fingers are protected during play. Maximum load 50 kg.

Mini Top | Art 2099

Made of: HDPE.	Age	Product size (cm)			Single unit box weight kg	Single unit box volume m ³	Number of units in export carton	Export carton weight kg	Export carton volume m ³
		Ø	L	W					
	0-4	68			1.80	0.120	16	28.60	0.302

Soft cushion intended to make infants feel safe and comfortable in the Mini Top.

Cushion for Mini Top | Art 2098

Made of: Quilted fabric with non-slip rubber dots on the bottom side.	Age	Product size (cm)			Single unit box weight kg	Single unit box volume m ³	Number of units in export carton	Export carton weight kg	Export carton volume m ³
		Ø	L	W					
	0-2	64			0.40	0.010	8	3.70	0.041



Scan QR for more inspiration.

Design: Harrit & Sørensen
 EU Design Registration No. 2155747-0005
 Patent No. ZL20133028054.3



The vertical edge protects the child's fingers and head from getting squashed.



The cushion is made from quilted fabric with non-slip rubber dots on the bottom side.



TOP

A wonderful giant top for hours of indoor and outdoor fun, with capacity for up to two children. Its durable construction lends itself to a host of activities, from rocking side to side to spinning to building a den. Smaller children can even use it as a boat in a pool under the supervision of an adult. The Top is designed to develop physical coordination, and is particularly well suited to children with disabilities. Maximum load 100 kg.

Top | Art 2100

Made of: HDPE.	Age	Product size (cm)			Single unit box weight kg	Single unit box volume m ³	Number of units in export carton	Export carton weight kg	Export carton volume m ³
		Ø	L	W					
6 pcs.	3-10	80		44	3.40	0.282	6	21.40	0.491

Top | Art 2101

Made of: HDPE.	Age	Product size (cm)			Single unit box weight kg	Single unit box volume m ³	Number of units in export carton	Export carton weight kg	Export carton volume m ³
		Ø	L	W					
30 pcs.	3-10	80		44	3.40	0.282	30	115.00	1.758



Scan QR for more inspiration.



1



2



3



4

Only the original Top is designed with a pointed centre, enabling children to experience the feeling of turning upside-down when revolving around the centre (photo 1). The raised edges protect children's heads and fingers from being hurt (photo 2 and 3), and there is no risk of suffocation when hiding inside the top (photo 4)







KOALA

Koala is a decorative toy with a wealth of possibilities designed to stimulate the vestibular sense and develop improved balance. Children can sit inside and rock or spin around like a carousel, or they can turn it upside down to use it as a den. Several Koalas can be combined into a play tunnel. The exterior has a circular moulding that prevents the Koala from rolling around, which could lead to children falling out or catching their fingers.

Maximum load 50 kg.

Koala | Art 2097

Made of: 8 mm thick HDPE.	Age	Product size (cm)				Single unit weight kg	Single unit volume m ³	Number of units in export carton	Export carton weight kg	Export carton volume m ³
		Ø	L	W	H					
	1-6	65		45		3.40	0.190	4	15.20	0.208

Design: Hanspeter Steiger

EU Design Registration No. 2418848-0001

Patent No. ZL 2014 3 02400249.0



Scan QR for more inspiration.



KOALA NON-SLIP SHOES

Koala Non-slip Shoes fit easily onto the feet of the Koala to provide extra safety during play.

Koala Non-slip Shoes | Art 2095

Made of: TPE.	Age	Product size (cm)				Single unit weight kg	Single unit volume m ³	Number of units in export carton	Export carton weight kg	Export carton volume m ³
		Ø	L	W	H					
Set of 3 pcs.	1-6	19	5	2.5		0.15	0.000	4	0.70	0.002



BABY TRAMPOLINE

Baby Trampoline is beautifully designed to offer simplicity and safety in a solid construction. The canvas, just 18 cm above the floor, is tensioned such that even small children will experience a springing effect, which they would be too light to feel on ordinary trampolines. The rubber cover yields protection against the metal frame, and the supporting handles are covered with foam to protect face and teeth. Maximum load 20 kg.

Baby Trampoline | Art 2406

Made of: Steel, TPE and PU foam. For indoor use only.	Age	Product size (cm)			Single unit box weight kg	Single unit box volume m ³	Number of units in export carton	Export carton weight kg	Export carton volume m ³
		Ø	L	W					
	1½-4	74		18/65	11.00	0.113	1	11.00	0.113

Design: Harrit & Sørensen



TRAMPOLINE

We think this trampoline is probably the most beautiful and well-designed trampoline ever seen in the childcare sector. The foam covered handles and sloped protective cushion with a high rear edge (11 cm) yield the utmost protection during play. Its durable construction from welded steel and a reinforced spring sheet, suspended with steel springs, ensures that it will provide endless hours of jumping and fun.

Maximum load 25 kg.

Trampoline | Art 2400

Made of: Steel, TPE and PU foam. For indoor use only.	Age	Product size (cm)			Single unit box weight kg	Single unit box volume m ³	Number of units in export carton	Export carton weight kg	Export carton volume m ³
		Ø	L	W					
	3-5	103		31/78	23.10	0.198	1	23.10	0.198

Design: Harrit & Sørensen



OUT-GROWN RATHER THAN THROWN AWAY...

GONGE® products are made to offer hours of fun for countless children for many years, and so we are always pleased when we see signs of wear on our products. A worn GONGE® product may not look as bright, shiny and clean as it did in the beginning, but that’s actually good, because scuffs, grazes and dirt show that children have been playing with the product and having fun.

What is the price per hour of physical activity when you buy a GONGE® product?

When we develop new products, we focus on high quality. We trust that most childcare professionals and parents realise that the cost of a product is not only a matter of price, but also of durability. Take a look at the products featured on this page, which have been exposed to daily wear and tear by numerous children over many years – with plenty more years to come! Are our products expensive? We don’t think so.

To us, sustainability is a question of how many hours of fun and physical activity we can create per kilo of plastic.

To comply with international safety standards, we always use virgin plastic raw material for our products, as recycled plastic often contains traces of phthalates and heavy metals. Manufacturing products with a long lifespan shows our commitment to responsible production from new plastics. And when, after many years enjoyment, the product is eventually worn out, icons engraved onto the product identify the type of high-grade plastic used, allowing it to be recycled.



#2117 Tactile Discs: Made in 2006 and still in use at the Vokseværket kindergarten, Aarhus, Denmark, in 2022.



#2101 Top: Made in 2011 and still in use at a public playground in Aarhus, Denmark, in 2022.



#2120 River Stones and # 2121 Hilltops. Made in 2012 and still in use in Springhallen, Risskov, Denmark, in 2022.



#2169 Seesaw: Made in 2011 and still in use at the Vokseværket kindergarten, Aarhus, Denmark, in 2022.

CAROUSEL

The exciting Carousel gives children a real spin! The seat is angled so that a child can propel the Carousel by shifting the body's centre of gravity, although younger children may find it easier to push off with their feet. Playing with the Carousel develops muscle integration, as well as strengthening them, and helps stimulate the vestibular sense in combination with sight to improve balance. The solid and stable metal base with rubber feet ensures safe spinning of the Carousel, and the seat's thick edge is easy to hold on to when in motion. Maximum load 50 kg.

Carousel | Art 2167

Made of: PP, TPE and steel.	Age	Product size (cm)				Single unit box weight kg	Single unit box volume m ³	Number of units in export carton	Export carton weight kg	Export carton volume m ³
		Ø	L	W	H					
	3-10	56		25		5.80	0.077	1	5.80	0.077

Design: Harrit & Sørensen

EU Design Registration No. 2418848-0002

Patent No. ZL 2014 3 0240250.3



Scan QR
for more
inspiration.







Scan QR
for more
inspiration.



AIR BOARD

A unique balancing board with a hard surface on a soft inflatable base, ideal for exercising motor control and strengthening muscles in the ankles, legs and upper body. The hard surface offers a safe grip for the feet while the inflatable base ensures smooth and gentle movements. The Gonge Air Board may be adapted to the functional level of the user by adjusting the pressure of the inflated air; increasing the pressure will speed up movements and make the balancing board more challenging. Manufactured using a newly developed, patent-pending production method, the multifunctional balancing board offers an elegant design and extra thick, hard-wearing surface. Suitable for play, training and rehabilitation at all ages. Maximum load: 100 kg.



Art 2179

Gonge Air Board | Art 2179

Made of: PP and TPE	Age	Product size (cm)			Single unit box weight kg	Single unit box volume m ³	Number of units in export carton	Export carton weight kg	Export carton volume m ³
		Ø	L	W					
	3+	39		12	1.65	0.016	6	10.2	0.051

Air Pump | Art 2184

	Age	Product size (cm)			Single unit box weight kg	Single unit box volume m ³	Number of units in export carton	Export carton weight kg	Export carton volume m ³
		Ø	L	W					
	3+	3	20		0.08	0.001	1	0.08	0.001

Design Harrit & Sørensen.
EU Patent No. 3501 61 2

CN Patent ZL 201822100536.7
UK Patent No. 90062671590003.



Art 2184





GIANT AIR BOARD

The Giant Air Board is an extremely versatile product. It can be used by people of all ages – for training and play. The Giant Air Board’s dimensions mean that children can play with it standing, seated and lying down.

The inflatable cushion gives the board a bouncy and mobile dimension not found in a regular balance board. The board tips on its inflatable base so that it can be used as a balance board or spring rider toy. This feature helps to make activities using the product more fun and unpredictable.

The Giant Air Board can be used for play and training with the coloured side up or down.

A Giant Air Board is ideal for play and building obstacle courses designed to improve motor skills, and as a supplement to many other Gonge products.

Maximum load 100 kg.

Giant Air Board | Art 2185

Made of: PP and TPE.	Age	Product size (cm)			Single unit box weight kg	Single unit box volume m ³	Number of units in export carton	Export carton weight kg	Export carton volume m ³
		Ø	L	W					
	3+	58		17	3.20	0.033	3	11.2	0.103

Design Harrit & Sørensen.
EU Patent No. 3501 61 2

CN Patent ZL 201822100536.7
UK Patent No. 90062671590003.



Scan QR
for more
inspiration.





SEESAW

The Seesaw is designed to provide a gentle and dynamic movement for children, stimulating their vestibular and proprioceptive senses as they sway back and forth. It features a non-slip surface and rubber mounds on the underside to help cushion the motion, as well as a rubber-covered base to protect the child from potential injury and floor damage.

Maximum load 75 kg.

Seesaw | Art 2169

Made of: PP and TPE.	Age	Product size (cm)			Single unit box weight kg	Single unit box volume m ³	Number of units in export carton	Export carton weight kg	Export carton volume m ³
		Ø	L	W					
	2+	54	22	14	1.90	0.021	6	12.40	0.145

Design: Harrit & Sørensen

Patent No. ZL 202330261178.1





GIANT BALANCING BOARD

The Giant Balancing Board is suitable for indoor or outdoor use, and is perfect for spinning around and rocking from side to side, whether sitting or standing. Equipped with a non-slip profile and four integrated handles, the board helps develop balancing skills and motor controls.

Maximum load 60 kg.

Giant Balancing Board | Art 2102

Made of: HDPE.	Age	Product size (cm)				Single unit box weight kg	Single unit box volume m ³	Number of units in export carton	Export carton weight kg	Export carton volume m ³
		Ø	L	W	H					
	3-10	76			14	5.00	0.112	15	64.00	0.399



ROCK AROUND

The Rock Around is designed to develop physical coordination skills. It is suitable for indoor and outdoor play, with capacity for up to two children, who can sit, spin around and rock from side to side. Users can hold on to the rim without the fear of catching their fingers between the rim and the floor.

Rock Around | Art 2104

Made of: HDPE.	Age	Product size (cm)				Single unit box weight kg	Single unit box volume m ³	Number of units in export carton	Export carton weight kg	Export carton volume m ³
		Ø	L	W	H					
	1-5	75			14	2.10	0.079	30	65.00	0.399



ROUND SEESAW

Children are amused and excited by the Round Seesaw's ability to move in all directions. The Round Seesaw is particularly suited for smaller children and can be used by one child alone or two children simultaneously. The robust handles are covered with soft foam. Maximum load 60 kg.

Round Seesaw | Art 2106

Made of: HDPE with foam covered handles of metal.	Age	Product size (cm)				Single unit box weight kg	Single unit box volume m ³	Number of units in export carton	Export carton weight kg	Export carton volume m ³
		Ø	L	W	H					
	3-8	76			14/60	8.00	0.112	1	8.00	0.112

BALANCO

Balanco is the perfect tool for play, sports training, and therapeutic treatments, designed to improve coordination, mobility, and posture. The user stands on the platform and shifts or twists their weight in order to move the ball around and solve various mazes or puzzles. For extra support, users can utilize Balanco's straps (Art 2942). This system is tailored towards two levels of difficulty and each set contains three different, interchangeable elements with their own unique puzzles. Maximum load 120 kg.



Balanco | Art 2142

Made of: HDPE Mouse game, Horizontal Eight and Maze.	Age	Product size (cm)			Single unit box weight kg	Single unit box volume m ³	Number of units in export carton	Export carton weight kg	Export carton volume m ³
		Ø	L	W					
	3+	55	42	16	4.50	0.037	5	23.00	0.164

Balanco Straps | Art 2942

Made of: HDPE and polyester.	Age	Product size (cm)			Single unit box weight kg	Single unit box volume m ³	Number of units in export carton	Export carton weight kg	Export carton volume m ³
		Ø	L	W					
	3+				0.16	0.001	1	0.16	0.001

WIPPSIDER

WippSider offer a sensomotoric exercise system for balancing reactions and motor control. It is simple in operation but challenging to master, motivating children to persevere until they succeed. Maximum load 120 kg.



WippSider | Art 2181

Made of: HDPE.	Age	Product size (cm)			Single unit box weight kg	Single unit box volume m ³	Number of units in export carton	Export carton weight kg	Export carton volume m ³
		Ø	L	W					
	3+	52	13	9	0.70	0.006	12	9.40	0.086

THERAPY TOP

Therapy Top | Art 2140

Made of: HDPE. Rippled surface.	Age	Product size (cm)			Single unit box weight kg	Single unit box volume m ³	Number of units in export carton	Export carton weight kg	Export carton volume m ³
		Ø	L	W					
	4+	40		9	1.30	0.014	6	8.50	0.089

THERAPY TOP - EPP

The existing Therapy Top made from EPP (Expanded Poly Propylene) which is a light, robust foam free from harmful substances and 100% recyclable.

Therapy Top | Art 2144

Made of: EPP. Rippled surface.	Age	Product size (cm)			Single unit box weight kg	Single unit box volume m ³	Number of units in export carton	Export carton weight kg	Export carton volume m ³
		Ø	L	W					
	4+	40		9	1.30	0.014	6	8.50	0.089



Art 2140



Art 2144

MINI STILTS

The Mini Stilts are especially developed for younger children and are easier to use than traditional wooden stilts. The handles can be adjusted to the height of the child, while also allowing a parent or older child to offer extra stability. The height of the platform can be adjusted from 3 to 15 cm using the loose plateaus, which can be easily added or removed by small children.

Maximum load 100 kg.



Mini Stilts | Art 2195

Made of: PP and TPE.	Age	Product size (cm)			Single unit box weight kg	Single unit box volume m ³	Number of units in export carton	Export carton weight kg	Export carton volume m ³
		Ø	L	W					
	3-7	26.5	17	70.5	3.50	0.037	4	15.00	0.165

Design: Harrit & Sørensen

EU Design Registration No. 2155747-0001.

Patent No. ZL201230340311.4



HEMISPHERE STILTS

Hemisphere Stilts adapt to the child's walking movement in a natural way, as they get to grips with balancing and stepping forwards or backwards.

Maximum load 100 kg.

Hemisphere Stilts | Art 2219

Made of: ABS and polyester with anti-slip rubber profile.	Age	Product size (cm)			Single unit box weight kg	Single unit box volume m ³	Number of units in export carton	Export carton weight kg	Export carton volume m ³
		Ø	L	W					
	5-8	15		8	0.40	0.006	12	5.60	0.051



BALANCE PLASTIC HEMISPHERES

Balance Plastic Hemispheres are a challenge to anyone's balancing skills, and can be used either side up to vary the difficulty. The Hemispheres are weighted with sand and have an anti-slip rubber profile. They can withstand damp if left outdoors. Maximum load 100 kg.

Balance Plastic Hemisphere | Art 2128

Made of: ABS and sand. With anti-slip rubber profile.	Age	Product size (cm)			Single unit box weight kg	Single unit box volume m ³	Number of units in export carton	Export carton weight kg	Export carton volume m ³
		Ø	L	W					
Set of 6 pcs. in 3 colours.	3+	15		8	5.40	0.011	4	22.30	0.054



Scan QR for more inspiration.





ACTIVITY RINGS

The brightly coloured Activity Rings appeal to children of all ages – and even to adults. They can be used as inspiration for countless activities such as dancing in a circle, walking on tiptoe in the rings, balancing the rings on your head, juggling rings on arms and legs, throwing rings to each other, jumping with rings around your legs, building figures – the combinations are limitless. The rings can be used in both spontaneous and structured activities during play, rhythmic and gymnastics. Suitable for individual as well as social activities.



Activity Rings | Art 2190

Made of: TPE.	Age	Product size (cm)			Single unit box weight kg	Single unit box volume m ³	Number of units in export carton	Export carton weight kg	Export carton volume m ³
		Ø	L	W					
Set of 6 pcs. in 6 colours.	1½+	16.4			0.35	0.002	12	4.70	0.043

Activity Rings | Art 2191

Made of: TPE.	Age	Product size (cm)			Single unit box weight kg	Single unit box volume m ³	Number of units in export carton	Export carton weight kg	Export carton volume m ³
		Ø	L	W					
Set of 24 pcs. in 6 colours.	1½+	16.4			1.30	0.005	6	8.50	0.061

EU Design Registration RCD 0027372588-0001. Patent No. ZL 2015 3 0255745.8



Scan QR for more inspiration.



CLOWN'S HAT

Concentration and balance are required to wear the Clown's Hat, which develops body consciousness and attention to posture. Children enjoy the individual challenge, as well as competitive scenarios. The shape, design and soft parts make it easy and safe to use for small children.

Clown's Hat | Art 2127

Made of: TPE rubber and EVA foam.	Age	Product size (cm)				Single unit box weight kg	Single unit box volume m ³	Number of units in export carton	Export carton weight kg	Export carton volume m ³
		Ø	L	W	H					
Set of 5 pcs.	3-8	17		19		0.40	0.002	12	5.20	0.034

Design: Harrit & Sørensen
 EU Design Registration No. 001248967-005-008
 Patent No. ZL201230340444.1



Scan QR
 for more
 inspiration.









PARACHUTE

Playing with the parachute provides exercise for the whole body for all ages, and is a wonderful way to develop basic physical coordination. Made of colourful, lightweight, fire-resistant polyester with very strong handles, the parachute inspires many different games and activities. A strong 10 mm thick rope is sewn into the outer edge, allowing an almost unlimited number of people to play at the same time. Maximum load 10 kg.

Parachute 1.75 m | Art 2301

Perfect for indoor use in limited space. Made of: Polyester	Age	Product size (cm)			Single unit box weight kg	Single unit box volume m ³	Number of units in export carton	Export carton weight kg	Export carton volume m ³
		Ø	L	W					
8 handles.	2+	175			0.30	0.002	25	8.80	0.046

Parachute 3.5 m | Art 2302

Made of: Polyester	Age	Product size (cm)			Single unit box weight kg	Single unit box volume m ³	Number of units in export carton	Export carton weight kg	Export carton volume m ³
		Ø	L	W					
8 handles.	3+	350			0.83	0.003	24	21.40	0.091

Parachute 5 m | Art 2303

Made of: Polyester	Age	Product size (cm)			Single unit box weight kg	Single unit box volume m ³	Number of units in export carton	Export carton weight kg	Export carton volume m ³
		Ø	L	W					
12 handles.	3+	500			1.50	0.005	15	23.60	0.100

Parachute 6 m | Art 2304

Made of: Polyester	Age	Product size (cm)			Single unit box weight kg	Single unit box volume m ³	Number of units in export carton	Export carton weight kg	Export carton volume m ³
		Ø	L	W					
12 handles.	3+	600			2.00	0.008	10	21.40	0.100

Parachute 7 m | Art 2305

Made of: Polyester	Age	Product size (cm)			Single unit box weight kg	Single unit box volume m ³	Number of units in export carton	Export carton weight kg	Export carton volume m ³
		Ø	L	W					
16 handles.	3+	700			2.60	0.016	8	21.60	0.096



Scan QR for more inspiration.



2301 No string



2302-5 String



PARACHUTE ENCOURAGING EXERCISE

We are pleased to offer this book containing detailed descriptions of how parachutes can be used in educational settings, such as childcare centres and schools. It is full of ideas for fun and meaningful physical activities, as well as explaining how the games stimulate social and intellectual development. The book has 56 pages with colour illustrations, and is available in six languages.



PARACHUTE. ENCOURAGING EXERCISE (Art 2914)

DAS SCHWUNGTUCH ALS BEWEGUNGSMITTEL (Art 2915)

IL PARACADUTE GIOCHI IN MOVIMENTO (Art 2916)

EL PARACAÍDAS COMO UN INSTRUMENTO DE MOVIMIENTO (Art 2917)

LE PARACHUTE JEUX EN MOUVEMENT (Art 2918)

SPADOCHRON JAKO INSTRUMENT DO PORUSZANIA SIE (Art 2919)

MAGIC SCARVES

The light, nylon Magic Scarves come in four cheerful colours and can be used individually or in groups. The scarves can be thrown up in the air or swirled around. Children can even pretend to be ghosts by wearing the scarves over their heads.



Magic Scarves 66 cm | Art 2306

Set of 12 in 4 colours. Made of nylon.	Age	Product size (cm)			Single unit box weight kg	Single unit box volume m ³	Number of units in export carton	Export carton weight kg	Export carton volume m ³
		Ø	L	W					
	2+	66	66		0.10	0.001	25	2.60	0.018

Magic Scarves 138 cm | Art 2307

Set of 4 in 4 colours. Made of nylon.	Age	Product size (cm)			Single unit box weight kg	Single unit box volume m ³	Number of units in export carton	Export carton weight kg	Export carton volume m ³
		Ø	L	W					
	2+	138	138		0.10	0.001	25	3.20	0.024



RING TOSS

Ring Toss offers a traditional game in a unique, high quality design. The popular tossing game is challenging both physically and mentally, as it requires concentration and body control to assess the distance and throw the rings with precision, providing hours of fun and opportunities for competitions. The two included supports allow the game to be tilted at an angle to make it easier for very small children.

Ring Toss | Art 2908

Metal frame with TPE rubber rings.	Age	Product size (cm)			Single unit box weight kg	Single unit box volume m ³	Number of units in export carton	Export carton weight kg	Export carton volume m ³
		Ø	L	W					
	3+	50	50	18	1.50	0.005	8	14.00	0.049



Scan QR for more inspiration.



THROWING GAME

The Throwing Game has a functional yet elegant design made from quality materials. Children take turns to throw the soft juggling balls into the large, polyester bags mounted on the steel stand. Six juggling balls are included.

Throwing Game | Art 2907

Metal frame, PP, TPE and polyester.	Age	Product size (cm)			Single unit box weight kg	Single unit box volume m ³	Number of units in export carton	Export carton weight kg	Export carton volume m ³
		Ø	L	W					
	2-6	70		67	5.20	0.039	1	5.20	0.039



Scan QR for more inspiration.





BLOW LOTTO

A unique, highly amusing game that develops breathing control and lip muscles! The players take turns at blowing the ball from one hole to another, which requires control of the direction and speed of the ball. Nine holes show different pictures, which are also featured on the players' lotto cards. The first player to cover all pictures is the winner.

Blow Lotto | Art 2006

Age	Product size (cm)			Single unit box weight kg	Single unit box volume m ³	Number of units in export carton	Export carton weight kg	Export carton volume m ³
	Ø	L	W					
3-10	22	22	10	1.00	0.005	16	18.00	0.099

Design: Emil Wegger

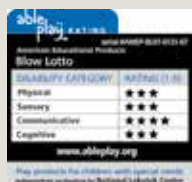



Seesaw
Art 2169 (page 69)



Roller
Arts 2266 / 2267 (page 19)



Airboard
Art 2179 (page 64)



Arches
Art 2163 (page 16)



Build N' Balance® Tilting Disc
Art 2233 (page 33)



Ring Toss
Art 2908
(page 82)



Activity Rings
Art 2190 (page 75)



Parachutes
Arts 2301-2305 (page 80)

ALSO FOR SENIORS

Several of our products are suitable for training and rehabilitation of adults and seniors.



Hilltops Nordic
Art 2821 (page 39)



River Stones Nordic
Art 2820 (page 38)



Giant Airboard
Art 2185 (page 67)



Nordic Tactile Discs
Art 2817 (page 46)



Nordic River
Art 2823 (page 42)

GONGE®

CURIOUS AND PLAYFUL SINCE 1966



1966 THE BEGINNING OF GONGE

In 1966, a school teacher handed his small company producing abacuses and other educational products over to a former pupil, Karen Margrethe Gonge, and her husband Jørgen. The GONGE family invested a lot of time and effort in learning about, and becoming experts in, these products.



1971 TRADING EDUCATIONAL RANGE FOR KINDERGARDENS

A couple of years later, the company began providing educational products for the growing number of kindergartens and, in 1971, the company commenced trading imported products to schools and kindergartens.

1966

1967

1971

1986



1967 INTERNATIONAL DIDACTA FAIR

Selling products that were quite new to the market was hard work, but the breakthrough came soon after the company's first appearance at the international Didacta Fair in 1967, cementing GONGE's belief in 'products for learning'.



1986 FROM PIONEER TO MARKET LEADER

GONGE grew from pioneer to a market leader in products targeting new educational trends, listening to teachers and professionals, and involving them in the selection of products. Acquiring of the mould for 'Tummelumsken' – a red spinning top – in 1984, sparked a significant change of direction, as the Top caused quite a sensation when it was presented to the international audience at the 1986 Nürnberg Toy Fair.



1991 FROM TRADING TO MANUFACTURER

In 1991, Jørgen Gonge decided to focus solely on the manufacturer of motor skill products, as the export business continued to grow with customers all over Europe and beyond. He then also decided to give up the trading company as an initial preparation for his retirement.

2010 A NATURAL MERGER WITH WINTHER

The continuous growth of the GONGE company called for an organizational change, and led to a harmonious merger with nearby Winther. The family-owned companies shared the same values, and both offer product ranges designed for 'Learning by Moving'. The merger led GONGE to relocate to Winther's headquarters in Them, near Silkeborg, in 2010.

1991 — 2001 — 2010 — 2020



2001 GENERATIONAL CHANGE

In 2001, his son, Henrik – who grew up listening to his parents talking about the products while he himself played with them – took up the position of general manager. This background, plus a doctorate in psychology, was to inspire Henrik's ongoing development of the brand.



2020 NORDIC COLLECTION

GONGE remain loyal to their origins as supplier to the educational market, yet their creative approach to learning has become increasingly popular with families as well. Therefore, GONGE developed a new Nordic collection that stylistically suits the trending Nordic interior while at the same time maintains the professional aspects of colour range and function.



winther
LEARNING BY MOVING®

GONGE is a subsidiary of A. Winther A/S · DK-8653 Them
Tel. +45 86 84 72 88 · www.gonge.com · gonge@gonge.com